



UNIVERSITY COLLEGE (UCTATI)

FINAL EXAMINATION QUESTION BOOKLET

COURSE CODE	: BME 2023
COURSE TITLE	: SOLID MECHANICS
SEMESTER/SESSION	: 1-2023/2024
DURATION	: 3 HOURS

Instructions:

1. This booklet contains **FIVE (5)** questions, answer **ALL** questions.
2. All answers should be written in answer booklet.
3. Write legibly and draw sketches wherever required.
4. If in doubt, raise up your hands and ask the invigilator.

DO NOT OPEN THIS BOOKLET UNTIL YOU ARE TOLD TO DO SO

THIS BOOKLET CONTAINS 10 PRINTED PAGES INCLUDING COVER PAGE

QUESTION 1

- a) A circular metal column is to support a load of 500 kN and must not compress more than 0.1mm. The modulus of elasticity is 210 GPa. The column is 3 m long.
- Describe** the modulus of elasticity (1 mark)
 - Compute** the cross sectional area of the column (3 marks)
 - Compute** the diameter of the column (1 mark)
- b) Shaft ABC is made of aluminium ($E= 75 \text{ GPa}$) with diameter of 50 mm. While Shaft CD is made of Steel ($E=200\text{GPa}$) with diameter of 30 mm. The rods experiencing loadings as shown in Figure 1.
- Compute** the force at each section F_{AB} , F_{BC} , F_{CD} (3 marks)
 - Compute** The deflection of section AB, δ_{AB} . (3 marks)
 - Compute** The deflection of section BC, δ_{BC} . (3 marks)
 - Compute** The deflection of section CD, δ_{CD} . (3 marks)
 - Determine** The total deflection at point D, δ_D . (3 marks)

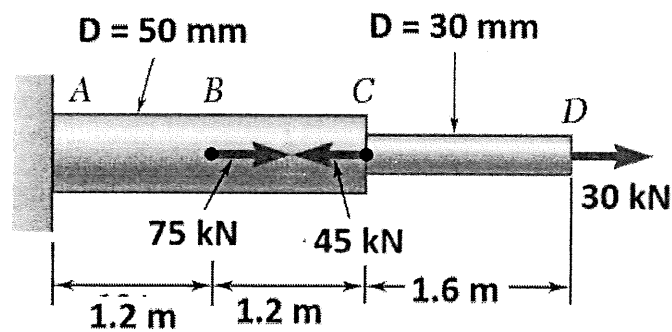

Figure 1

QUESTION 2

- a) A hollow steel shaft (modulus of rigidity = 80GPa) with a diameter ratio of 0.75 and length of 4 m is required to transmit 1 MW at 120 rev/min. The maximum shear stress is not exceeded 70 MPa nor is the overall angle of twist to exceed 1.75° .
- Explain** the meaning of modulus of rigidity (1 mark)
 - Determine** the necessary outer diameter (D_o) of the shaft (5 marks)
 - State** the actual constraint and its value (1 mark)
- b) Two horizontal shaft AD is attached to a fixed base at D and is subjected to the torques shown in Figure 2. A 40 mm diameter hole has been drilled into portion CD of the shaft. Knowing that the shaft AB is made of Aluminium ($G=27$ GPa) and shaft BD is made of brass in which $G=39$ GPa,
- Compute** the Polar moments of inertia of each portion (3 marks)
 - Compute** the torque of each portion (2 marks)
 - Compute** the angle of twist each portion (in degree) (6 marks)
 - Determine** the angle through end A rotates (in degree) (2 marks)

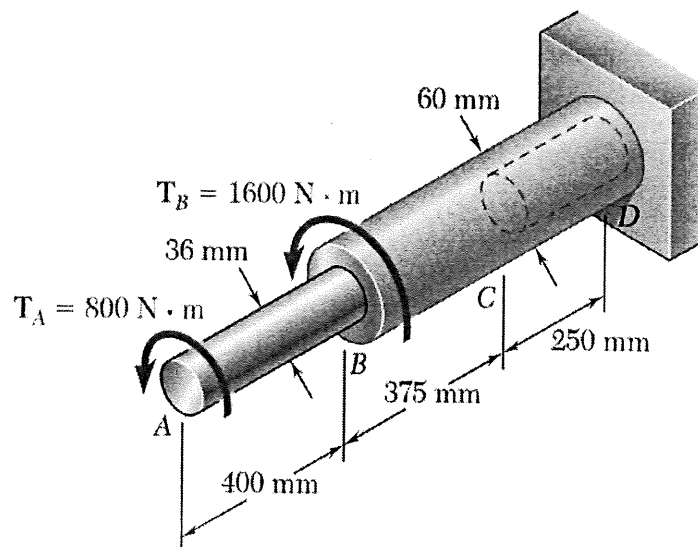

Figure 2

QUESTION 3

a) Two vertical forces are applied to a beam as shown in Figure 3.

- i. **Compute** the reaction values R_A and R_D (1 mark)
- ii. **Prove** that the maximum bending moment is 3.0 kNm (4 marks)

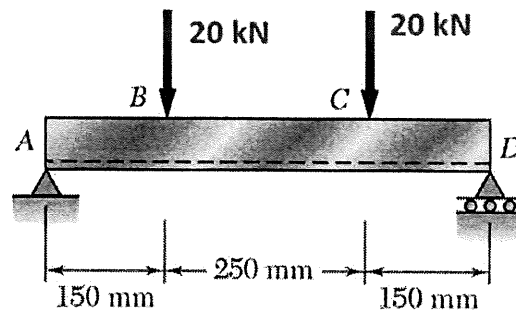

Figure 3

b) The structure in Figure 4 consists of a simply supported beam with loaded as shown. Knowing that the allowable normal stress for the grade of steel to be used is 160 Mpa.

- i. **Compute** the reaction values R_A and R_D (2 marks)
- ii. **Sketch** the free body diagram for the beam (2 marks)
- iii. **Sketch** the shear force diagram for the beam (4 marks)
- iv. **Sketch** the bending moment diagram for the beam (5 marks)
- v. **Solve** the minimum section modulus (S_x) (2 marks)

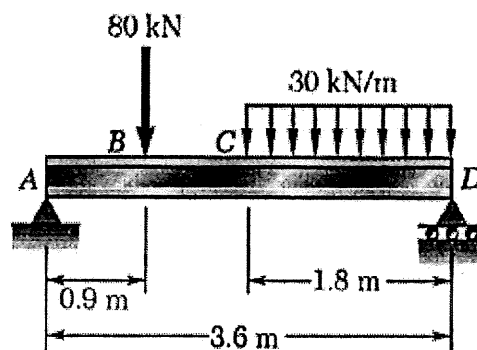

Figure 4

QUESTION 4

Two vertical forces are applied to a beam as shown in Figure 5. While, the cross sectional of the H-beam is shown as in Figure 6. If the maximum bending moment is 3.0 kN.m,

- Compute the area of the H-shape (4 marks)
- Determine the centroid of the H-shape (4 marks)
- Determine Centroidal moment of Inertia (I_{gg}) (4 marks)
- Compute Maximum Tensile stress (4 marks)
- Compute Maximum Compressive stress (4 marks)

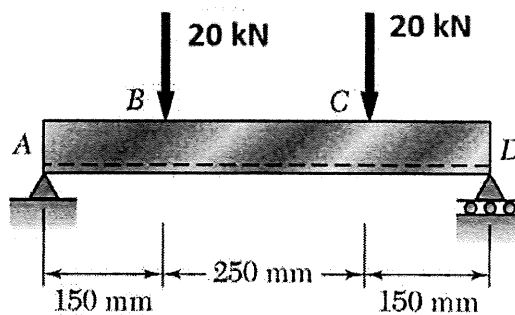

Figure 5

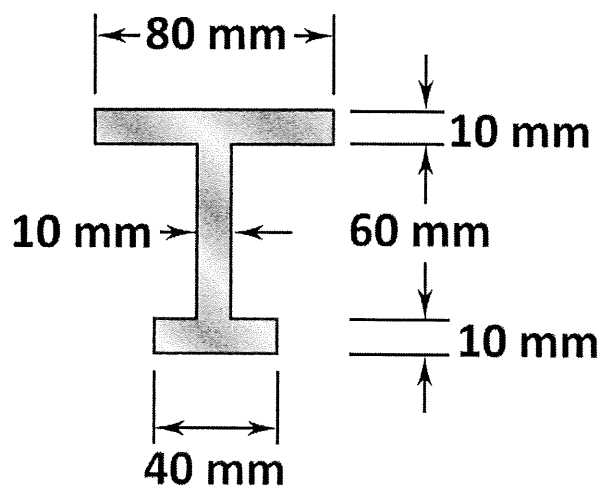

Figure 6

QUESTION 5

- a) The couple 1600 Nm is applied to a beam of the cross section in a plane forming an angle 30° with the vertical shown in Figure 7.
- Compute** the moment acted on both axis, M_y and M_z (2 marks)
 - Compute** second moment of inertia for both axis, I_y and I_z (2 marks)
 - Determine** the maximum tensile stress and its location (3 marks)
 - Determine** the maximum compressive stress and its location (2 marks)

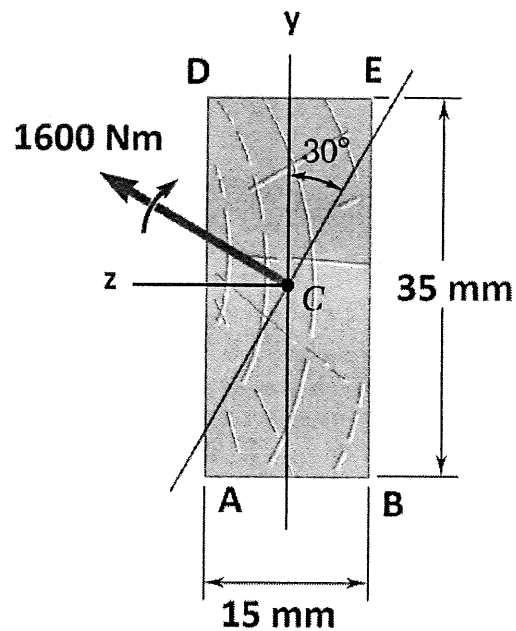

Figure 7

- b) Horizontal load P is applied to a short section of an S250 X 37.8 rolled-steel member as shown in Figure 8. Knowing that the compressive stress not to exceed 83 MPa.
- Identify** the area (A , m^2) and section modulus (S_x & S_y , m^3) of the S250x37.8 rolled steel member. (1 mark)
 - Compute** the force and couples at point C (In term of load P) (1 mark)
 - Compute** the stresses value σ_1 , σ_2 and σ_3 (in term of load P) (3 marks)
 - Compute** the stresses at point A, B, D and E (in term of load P) (4 marks)
 - Determine** the largest permissible load P (2 marks)

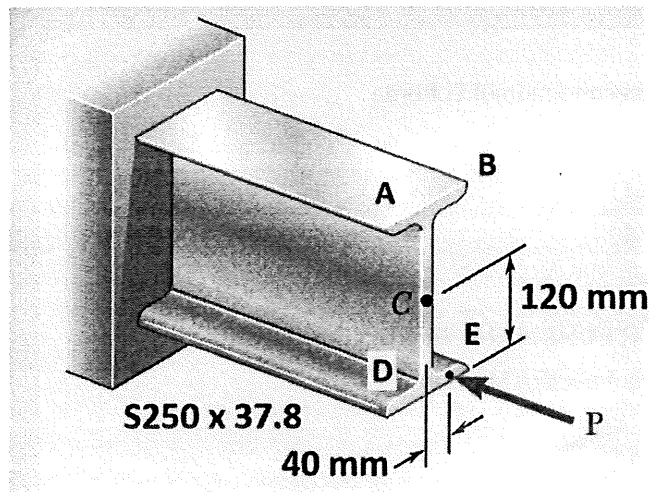

Figure 8

-----End of questions-----

Criteria	Marks
All questions answered will be marked according to the answer scheme	/100

FORMULA
STRESS STRAIN

Normal stress

$$\sigma = \frac{F}{A}$$

strain

$$\varepsilon = \frac{x}{L}$$

Modulus of Elasticity

$$E = \frac{\sigma}{\varepsilon}$$

Elongation

$$\delta = \frac{FL}{EA}$$

TORSION

Angle of twist

$$\phi = \frac{TL}{JG}$$

$$\frac{G\phi}{L} = \frac{T}{J} = \frac{2\tau}{D}$$

Power Transmission

$$P = 2\pi NT$$

Polar second moment of area

Solid

$$J = \frac{\pi D^4}{32}$$

Hollow

$$J = \frac{\pi(D^4 - d^4)}{32}$$

SHEAR FORCE AND BENDING MOMENT

Minimum section Modulus

$$S_{\min} = \frac{|M|_{\max}}{\sigma_{all}}$$

Relationship between load, shear and bending moment.

$$V_B - V_A = -wx \text{ (area under load curve between B and A)}$$

$$M_B - M_A = V \text{ (area under shear curve between B and A)}$$

BENDING STRESS

Centroid

$$\bar{Y} \sum A = \sum \bar{y} A$$

2nd Moment of area for rectangular shape

$$I = \frac{1}{12} b h^3$$

Parallel axes theorem

$$I_{ss} = I_{gg} + A d^2$$

Normal stress from neutral axis

$$\sigma = \frac{M y}{I}$$

NON SYMMETRIC BENDING

$$\sigma_1 = -\frac{F}{A} \quad \sigma_2 = \frac{M_x}{S_x} \quad \sigma_3 = \frac{M_y}{S_y} \quad \sigma_A = -\frac{M_z Y_A}{I_z} + \frac{M_y Z_A}{I_y}$$

$$\sigma = \pm \sigma_0 \pm \sigma_1 \pm \sigma_2$$

Properties of Rolled-Steel Shapes (S Shapes)

Designation†	Area <i>A</i> , mm ²	Depth <i>d</i> , mm	Flange		Web Thick- ness <i>t_w</i> , mm	Axis X-X			Axis Y-Y		
			Width <i>b_f</i> , mm	Thick- ness <i>t_f</i> , mm		<i>I_x</i> 10 ⁶ mm ⁴	<i>S_x</i> 10 ³ mm ³	<i>r_x</i> mm	<i>I_y</i> 10 ⁶ mm ⁴	<i>S_y</i> 10 ³ mm ³	<i>r_y</i> mm
S610 × 180	22900	622	204	27.7	20.3	1320	4230	240	34.5	338	38.9
158	20100	622	200	27.7	15.7	1220	3930	247	32.0	320	39.9
149	18900	610	184	22.1	18.9	991	3260	229	19.7	215	32.3
134	17100	610	181	22.1	15.9	937	3060	234	18.6	205	33.0
119	15200	610	178	22.1	12.7	874	2870	241	17.5	197	34.0
S510 × 143	18200	516	183	23.4	20.3	695	2700	196	20.8	228	33.8
128	16300	516	179	23.4	16.8	653	2540	200	19.4	216	34.5
112	14200	508	162	20.2	16.1	533	2100	194	12.3	152	29.5
98.2	12500	508	159	20.2	12.8	495	1950	199	11.4	144	30.2
S460 × 104	13200	457	159	17.6	18.1	384	1690	170	10.0	126	27.4
81.4	10300	457	152	17.6	11.7	333	1460	180	8.62	113	29.0
S380 × 74	9480	381	143	15.8	14.0	202	1060	146	6.49	90.6	26.2
64	8130	381	140	15.8	10.4	186	973	151	5.95	85.0	26.9
S310 × 74	9420	305	139	16.7	17.4	126	829	116	6.49	93.2	26.2
60.7	7680	305	133	16.7	11.7	112	739	121	5.62	84.1	26.9
52	6580	305	129	13.8	10.9	94.9	624	120	4.10	63.6	24.9
47.3	6010	305	127	13.8	8.89	90.3	593	123	3.88	61.1	25.4
S250 × 52	6650	254	125	12.5	15.1	61.2	482	96.0	3.45	55.1	22.8
37.8	4810	254	118	12.5	7.90	51.2	403	103	2.80	47.4	24.1
S200 × 34	4360	203	106	10.8	11.2	26.9	265	78.5	1.78	33.6	20.2
27.4	3480	203	102	10.8	6.88	23.9	236	82.8	1.54	30.2	21.0
S150 × 25.7	3260	152	90.7	9.12	11.8	10.9	143	57.9	0.953	21.0	17.1
18.6	2360	152	84.6	9.12	5.89	9.16	120	62.2	0.749	17.7	17.8
S130 × 15	1890	127	76.2	8.28	5.44	5.12	80.3	52.1	0.495	13.0	16.2
S100 × 14.1	1800	102	71.1	7.44	8.28	2.81	55.4	39.6	0.369	10.4	14.3
11.5	1460	102	67.6	7.44	4.90	2.52	49.7	41.7	0.311	9.21	14.6

